

# **Bow Tuning tests**

*Steve Ellison*

---

## **CONTENTS**

---

|   |           |
|---|-----------|
| <b>1. BASIC SET-UP .....</b>                        | <b>1</b>  |
| 1.1 BRACING HEIGHT .....                            | 1         |
| 1.2 NOCKING POINT .....                             | 1         |
| 1.3 CENTRE SHOT .....                               | 1         |
| 1.4 TILLER.....                                     | 1         |
| 1.5 BOW MEASUREMENTS .....                          | 2         |
| <b>2. CLEARANCE CHECKS.....</b>                     | <b>3</b>  |
| 2.1 INSPECTION .....                                | 3         |
| 2.2 CONFIRMATORY TESTS .....                        | 4         |
| 2.3 OTHER SYMPTOMS .....                            | 4         |
| 2.4 CURING CLEARANCE PROBLEMS .....                 | 4         |
| <b>3. BASIC TUNING CHECKS.....</b>                  | <b>6</b>  |
| 3.1 BASIC NOCKING POINT AND CENTRE SHOT CHECK ..... | 6         |
| 3.2 SIMPLE BUTTON ADJUSTMENT .....                  | 7         |
| <b>4. TILLER ADJUSTMENT .....</b>                   | <b>8</b>  |
| 4.1 STATIC TILLER ADJUSTMENT.....                   | 8         |
| 4.2 DYNAMIC TILLER ADJUSTMENT .....                 | 8         |
| 4.3 ADJUSTING FOR 'FEEL' .....                      | 8         |
| <b>5. ADVANCED TUNING TESTS.....</b>                | <b>9</b>  |
| 5.1 BARE SHAFT PLANING TEST .....                   | 9         |
| 5.2 PAPER TEAR TEST .....                           | 10        |
| 5.3 WALK-BACK TEST .....                            | 11        |
| <b>6. TUNING FOR GROUPS.....</b>                    | <b>13</b> |
| 6.1 SHORT DISTANCE FINE TUNING .....                | 13        |
| 6.2 FINE TUNING - PAPER PLATE METHOD .....          | 15        |
| 6.3 MICRO TUNING - MCKINNEY/RABSKA METHOD .....     | 16        |
| <b>7. BOOKS AND REFERENCES .....</b>                | <b>17</b> |

# 1. Basic set-up

---

## **1.1 Bracing height**

Bracing height should initially be set according to the manufacturer's recommendation. Matthews (Matthews 1980) suggests setting the bracing height in the upper half of the recommended range, initially, to help guarantee good arrow clearance and a forgiving shot. This is a good rule for initial set-up.

Better speed is attained with lower bracing height, but at the risk of a 'critical' shot. As set-up and tuning progresses, it may be worth reducing the bracing height to explore the practical operating range. Bracing height is most easily assessed on the basis of the sound of the shot; the bow will become progressively more noisy as the bracing height moves away from the optimum. Part of that results from increased string impact on the bow limb recurve. Perhaps equally importantly, the bracing height affects the point at which the arrow leaves the string, and careful adjustment can locate points where the arrow leaves most cleanly. Sound is the most direct guide; arrow flight may also be an indication, but this is better dealt with by fine or micro tuning methods (section 6)

## **1.2 Nocking point**

The nocking point should initially be set 3-5mm higher than the arrow rest (Figure 1-1). Use a bracing height gauge to set the nocking point.

An alternative rule of thumb is to check the tiller setting (below), and set the nocking point at the same height above the rest as the difference between top and bottom tiller measurements. For example, if the difference (a-b) in Figure 1-3 is 4mm, set the nocking point 4mm high.

## **1.3 Centre shot**

A recurve bow or compound bow shot with fingers should initially be set up as shown in Figure 1-2.b), that is, with the shaft slightly to left of the string line and the sight vertically above the shaft. Either button position or arrow rest/launcher may be adjusted to achieve this. Compounds shooting release aids should adjust initially for exact alignment of string and shaft, analogous to Figure 1-2.a)

## **1.4 Tiller**

Tiller is normally set by the manufacturer or sales outlet, and need not be altered on basic set-up. If necessary or desired, tiller may be adjusted to a starting position to suit the archer or for observable 'balance' by one of the methods at section 4 (Tiller adjustment).

## 1.5 Bow measurements

The diagrams below (Figures 1-1 to 1-3) show the bow measurements and adjustments most important for basic bow set-up.

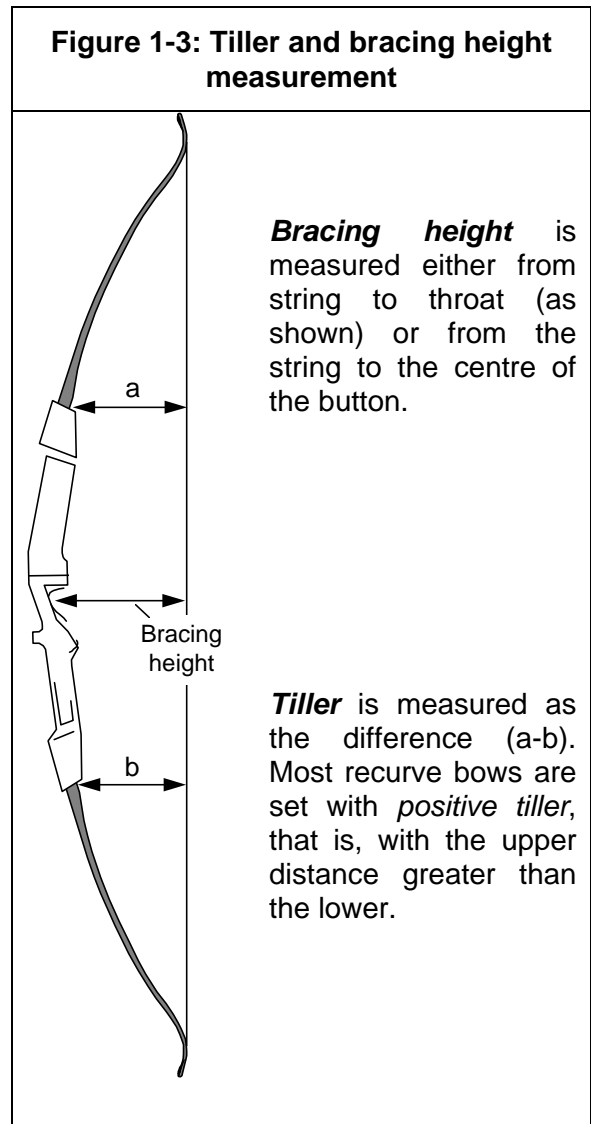
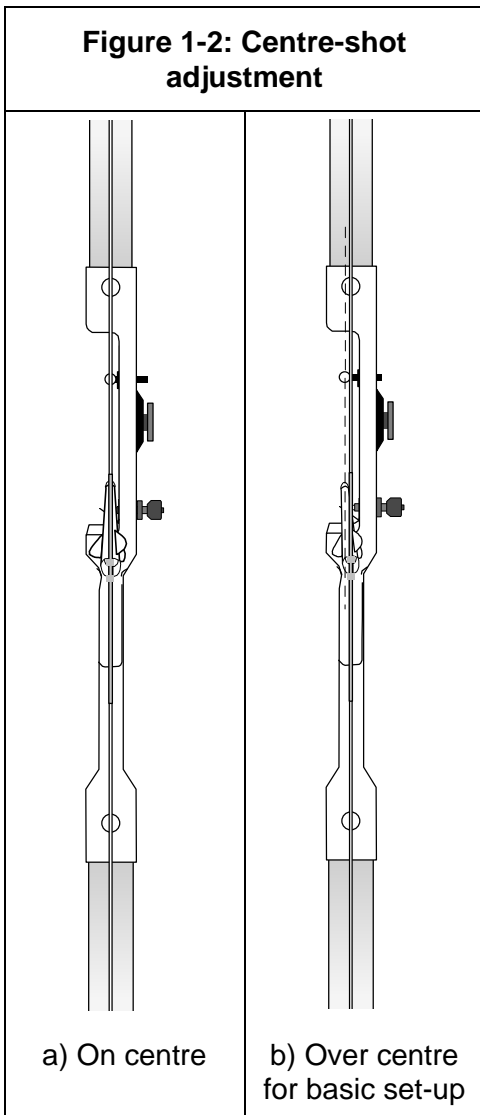
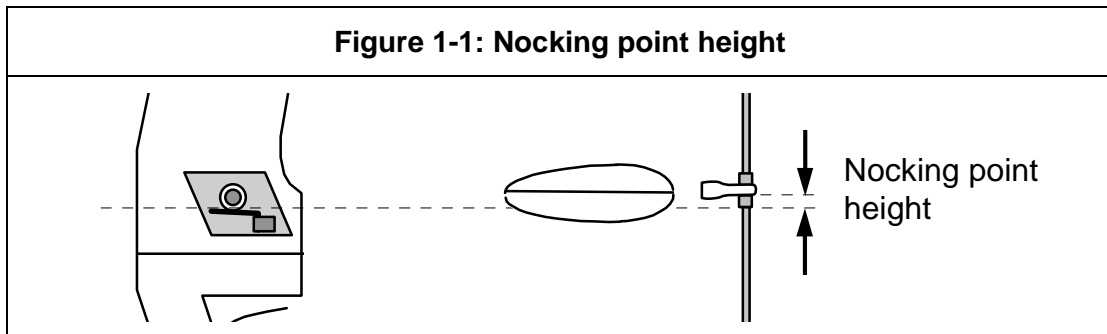

## 2. Clearance checks

The barest minimum requirement for acceptable bow performance is adequate clearance. That is, the arrow should leave the bow with no contact other than with the arrow rest early in the shot. Any other contact is likely to lead to very poor arrow flight. Worse, marginal clearance can lead to very variable shooting, as a poorer shot than usual impacts the bow hard, while better shots leave unimpeded. Clearance problems should be eliminated before tuning the bow, though it is possible that very poor initial adjustment can generate clearance problems which are resolved by adjustment. The following tests can be used to check for and confirm clearance problems.

### 2.1 Inspection

Visual inspection is one of the simplest checks for clearance problems. Bow and arrows may show evidence of undue contact; the following sections show what to look for.

#### 2.1.1 Arrows

Carefully study shafts and fletchings. Symptoms of clearance problems generally show most prominently towards the rear of the shaft. The symptoms will show on all shafts shot regularly, so examine several. Isolated instances are likely to be due to normal wear and tear from targets and other arrows hitting the target; *consistent* markings on a set of shafts indicate clearance problems. Look for:

- Wear marks along the shaft, anywhere in the back half, particularly near the fletchings. Evidence of scratch marks along the shaft, thinner anodised finish, polishing or rubbing marks indicates contact. Clearance problems show, as expected, most commonly on the side of the shaft normally in contact with the pressure point or arrow rest.
- Worn, marked or damaged fletchings. For recurves, the lower fletching (closest to the arrow rest) is most vulnerable, but both the bow side fletchings may show marks. Look for consistent wear marks, streaks, tears, or folds. Note that folds and bends can also be caused by the arrow holder in the equipment case.

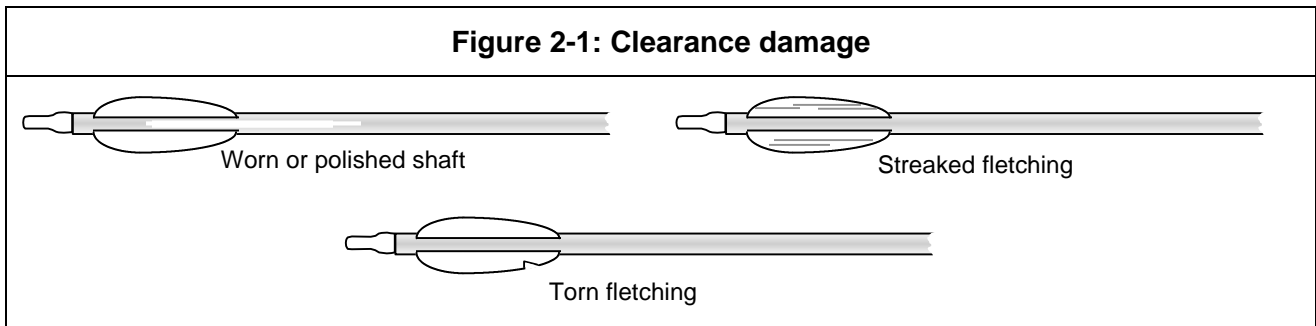

#### 2.1.2 Bows

Examine the arrow rest, clicker, pressure button, bow window and sight bar. Check for:

- Streaks, wear marks or dents anywhere, especially around the bow window, near the rest.
- Deposited plastic (from fletching contact) on sharp edges like arrow rests, clicker and sight bar.
- Heavy button wear, especially away from the normal contact point at rest (for example, the shaft is normally set up approximately centrally on the button; heavy wear near the edges may suggest clearance problems.
- Noise on the shot; impact is often quite audible.

## **2.2 Confirmatory tests**

### ***2.2.1 Dusting***

Apply a coating of talc, finely powdered chalk, or spray talc around the bow window near the rest, and/or to fletchings and arrow shafts. Shoot a few arrows, and inspect the powder. Shaft contacts will show as disturbances - streaks or, sometimes, neat 'fletching' marks in the dust.

### ***2.2.2 Modelling clay***

Apply a thin layer of plasticine or other soft (and removable!) modelling clay to the bow window, just behind the arrow rest. Make sure it does not protrude significantly beyond the rest. Shoot a few shafts, and look for contact marks on the modelling clay.

## **2.3 Other symptoms**

Though all of the symptoms below have many causes - mostly down to the archer - they may, in conjunction with other symptoms, indicate an arrow clearance problem.

- Visibly bad arrow flight; spiralling or extreme fishtailing
- Poor short distance grouping
- Impact noise on shooting
- Frequent arrow rest replacement
- Clicker frequently knocked forward or bent
- Extreme 'flyers' in otherwise consistent shooting

## **2.4 Curing clearance problems**

Clearance problems arise from a variety of causes, including poor shooting technique (particularly with respect to the string hand). The main equipment-related causes and the corrections which might be needed are considered here, in approximately increasing order of complexity.

### ***2.4.1 Over-tight nocking point***

Check that the nocks leave the string smoothly and easily. Over-tight nocks will very often cause the tail of the shaft to contact the bow. Correct over-tight nocks by

- Increasing nock size
- Reducing string thickness (fewer strands or thinner centre serving)

Filing nocks is not to be recommended; it is too difficult to match replacement nocks.

### ***2.4.2 Low nocking point***

A very low nocking point may cause impact problems; adjust the nocking point to 3mm or more above the arrow rest for initial set-up. Check using a basic set-up test (for example, section 3).

### ***2.4.3 Extreme button position***

Check the button position; set the button just outside centre shot for initial set-up (see Figure 3-2).

### ***2.4.4 Incorrect bracing height***

Poorly set - especially low - bracing height can cause or exacerbate clearance problems. Check that the bracing height is within the range specified by the manufacturer. If there is scope, increase the bracing height to the top of the range by fitting a shorter string and check clearance again.

### 2.4.5 Over-size arrow rest

An arrow rest with over-long arm or other protuberances is a common cause of interference. Corrective actions may include:

- Trimming the support arm (or other parts) to the minimum required (Figure 2-2)
- Changing to a lower profile rest, or 'under-arrow' rest
- Changing to a drop-away rest (a rest which moves downwards or inwards, triggered by the movement of the shot or under spring tension).
- Removing or protecting sharp edges. Some rests increase clearance problems by 'catching' fletchings on sharp edges. Ideally, the possibility of impact should be avoided entirely, but it may be possible to reduce the effect by taping over or removing protuberant edges.

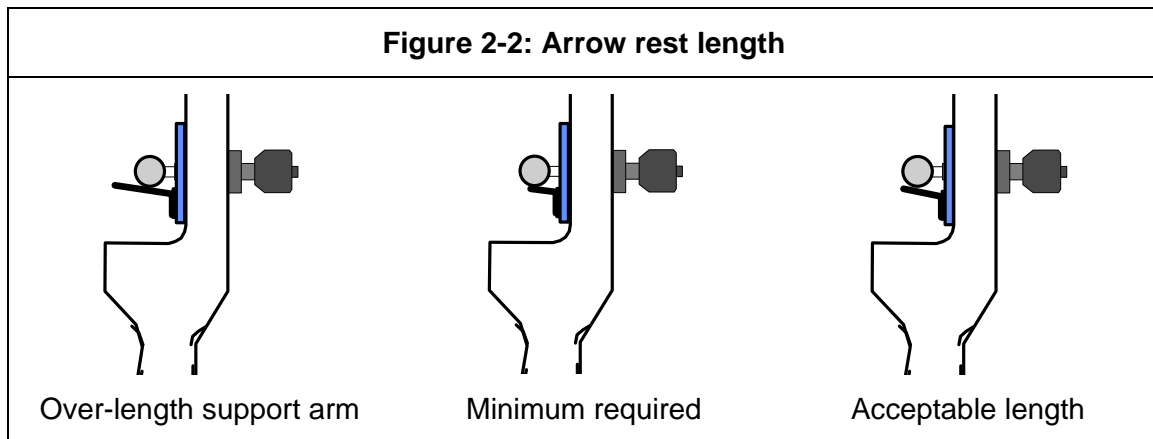

### 2.4.6 Poor spine matching

Arrows too whippy or (less commonly) too stiff for the bow may cause clearance problems. In general, wear marks towards the rear of the shaft indicate excessively high spine rating (whippy shafts). Check the specification against the actual draw weight of the bow, and if possible, check by shooting alternative shaft specifications. Corrective actions include:

- Changing arrow specification (a new set of arrows)
- Adjusting the draw weight of the bow to improve the bow/arrow match.
- Using different point weights can adjust effective spine slightly. Heavier points lead to an effectively higher spine rating ('whippier' shaft) and vice versa.
- Changing string material. Fast, low-stretch string materials (Kevlar, Fast-flite, Dyneema etc.) make the shaft effectively more whippy.
- Changing limb material. Faster (usually Carbon) limbs will increase the effective spine rating (whippier shaft)

### 2.4.7 Extreme tiller mis-set

Bow tiller set to extreme values may lead to clearance difficulty. Additional symptoms will include extreme 'kick' - for example, the long rod may kick upward (or downward) hard - and/or lengthy vertical limb vibration after the shot. Corrective action, (where possible) is to adjust tiller using either limb adjustment or packing material.

### 3. Basic tuning checks

#### 3.1 Basic Nocking Point and centre shot check

This quick test gives a fair 'coarse alignment' check. Simply shoot an arrow horizontally at a target from a distance of about 3-5 yards. Observe whether the tail of the arrow 'lays over' to left or right, or is high or low.

This test is more sensitive using a bare shaft instead of a fletched shaft.

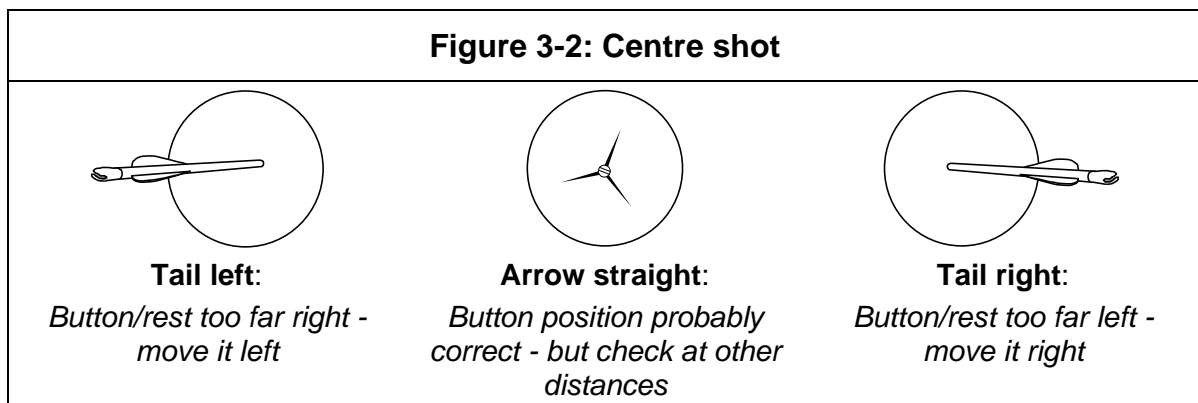
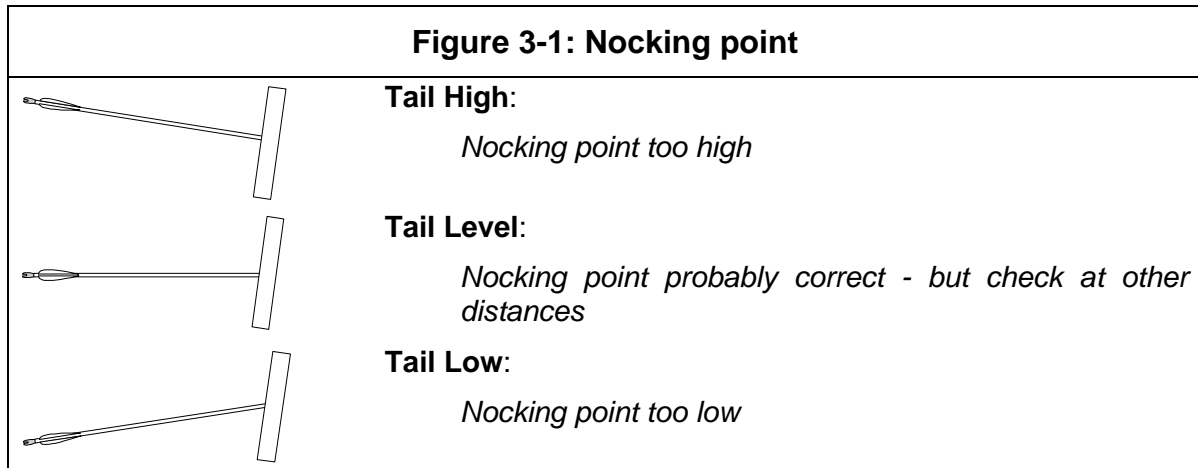

#### Notes:

1. To check that you are shooting horizontally:

*Either* get someone else to check by watching from the side

*or* put an aiming mark at your eye level, another at your chin height (about 4 inches/10cm below the first), and adjust your sight until your arrow hits the lower mark when aiming at the upper.

2. It is best to check by shooting several arrows, into different places on the target. The target construction can sometimes cause an arrow to penetrate at an angle, even if it hits straight.

3. If the test looks right, check at one or two other distances, say 3 and 7 yards. If these are right too, things are about right. If not, adjust until the shafts are straight at several distances, or use a different test.

4. All these checks assume reasonably well matched shafts; they will not work well with arrows poorly matched to the bow.

5. Nocking point adjustment is also affected by tillering; tiller adjustment may be out if the nocking point is hard or impossible to adjust.

## 3.2 Simple Button Adjustment

This simple adjustment is a good, quick set-up exercise for button position and tension, following nocking point setting by other means. It uses ordinary, fletched shafts shot at a standard target at about 20 yards (18m). Instructions as follows:

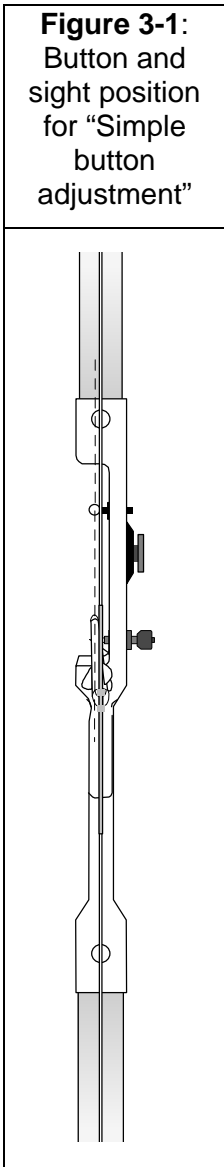

1. Set the button to give a shaft position just outward from centre-shot as seen from directly behind the bow (Figure 3-1, to right, for R/H archer).
2. Set the sight vertically above the shaft (see diagram)
3. Shoot at 20 yards at a normal target or aiming mark. Adjust the *button spring tension only* until the group centre is vertically in line with the aiming point (i.e. they land where they are aimed!). (See Figure 3-2)

### Notes.

1. This button tension adjustment can also be used following a button position check, such as the bare shaft planing test or paper tear test. If so, leave the button position as adjusted in the prior test, rather than changing it to fit in with step 1 above.
2. As with all other quick adjustments, check for improved group size following the adjustment.

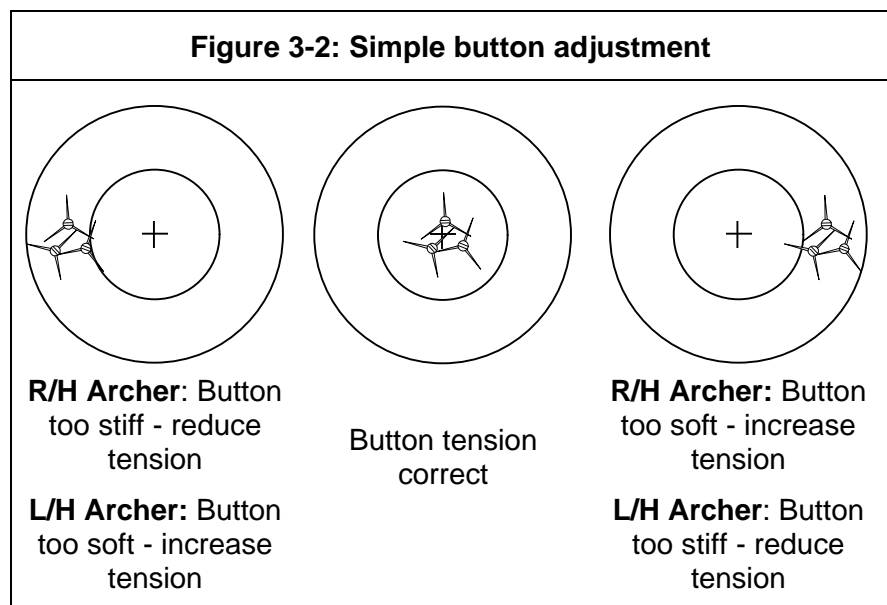



---

## 4. Tiller adjustment

---

Because the arrow leaves the bow somewhat above the pressure point, a symmetrical bow tends to kick upwards on release. To counter this effect, the lower limb is usually made or adjusted to be slightly stiffer than the upper limb, 'balancing' the bow better through the shot. This balancing act is commonly called 'tillering'. Tiller can be measured directly on most bows as the difference between distances from string to limb at the riser or 'fade-out' positions (Figure 1-3). Because the ideal tiller setting depends on the exact pressure point of the archer's hand on the bow, and is also influenced by stabilisation, tiller may need adjusting for best performance. The following sections suggest three methods of adjusting tiller; it is also possible (particularly for compound bows) to use micro tuning techniques to fine tune tiller (see section 6.2).

### **4.1 Static tiller adjustment**

McKinney (McKinney 1997) recommends adjusting tiller to give no sight movement during the draw; instructions are as follows:

- i) Standing 5-15 yards (m) from a 40-60cm face or other aiming point near eye level, lift the bow to pre-draw position and place the sight pin on the gold, with string hand level with the normal face reference (anchor position).
- ii) Draw directly back to the face reference point, slowly and without vertical movement of either hand and keeping the head still. Observe the behaviour of the sight pin.
- iii) If the sight pin drifts up, the top limb is too stiff: increase tiller slightly. If the pin drifts down, reduce tiller slightly.

It may be useful to have an independent observer watch the bow from the side.

### **4.2 Dynamic tiller adjustment**

This procedure adjusts tiller to give visually balanced bow behaviour on the shot.

- i) Set up the bow with a light long rod. Shoot the bow at any comfortable distance, and observe the behaviour of the tip of the rod and subsequent behaviour of the limbs.
- ii) If the rod kicks up instantly, increase tiller; if downwards, decrease the tiller. Repeat until the rod moves essentially straight forward. Take care to distinguish the natural bow movement from anything the archer does following the shot, and from natural forward or backward roll; look for the *instant* reaction to the shot.
- iii) During the exercise, monitor the limb behaviour. Vertical oscillation after the shot, which may show as the nocking point vibrating rapidly up and down, suggests tiller imbalance. This should be minimised by adjusting tiller as necessary.

### **4.3 Adjusting for 'feel'**

An alternative is to adjust tiller for subjective feel when shooting the bow (with stabilisers). Simply shoot for a while to get the feel of the bow, adjust tiller slightly and check out the feel. If there is no significant difference, return to the original setting; otherwise, adjust accordingly.

## 5. Advanced tuning tests

### 5.1 Bare Shaft Planing test

The “bare shaft planing” check is an alternative test for either nocking point height or centre shot. Since it uses only the position of impact, not the angle, it may be easier to work out what is going on than the simple fletched impact test above. It is also a good reference check; once fine-tuned for best group size, it is worth doing and recording a bare shaft planing test (without adjustment). Subsequent re-tuning can then simply adjust for the ‘best group’ bare shaft planing pattern previously recorded.

To carry out the test, set up an aiming mark at about eye level, and shoot 2-3 fletched shafts and one or more bare shafts at the same mark from 5 yards initially. The test can also be carried out from 10, 20 yards or more, and becomes more sensitive at longer distances. However, ‘fishtailing’ from a poorly adjusted bow may cause impact positions to alternate as the distance increases, so it is safest to start close and move back once basic adjustment is complete.

‘Ideal’ (note 1) nocking point height and centre shot leads to the bare shaft landing in the same place as fletched shafts; otherwise, the bare shaft behaves ‘worse’ than the fletched shaft, so the direction of bare shaft impact relative to the fletched shafts is an indication of the adjustment needed. The diagram below (Figure 5-1) shows the possibilities.

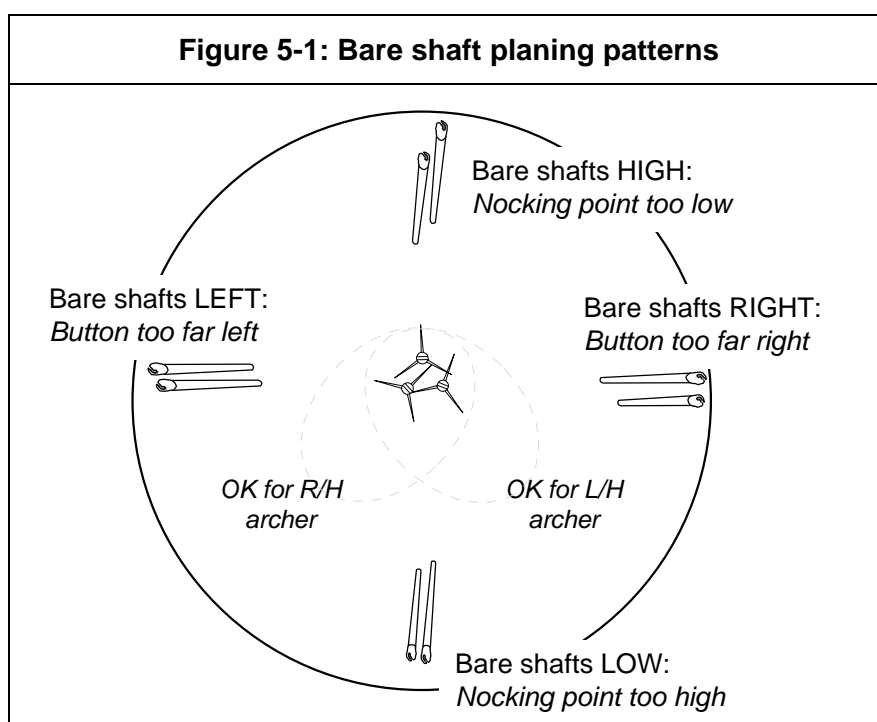

#### Notes

1. A ‘perfect’ bare shaft test is unlikely at longer distances. As a rule of thumb, a six-inch gap between bare shaft and fletched shaft positions is acceptable at 20 yards (but see note 2 - some positions are better than others).
2. Many top archers regard ‘ideal’ as potentially unforgiving. A common practice is to tune for a bare shaft impact slightly low and left of the fletched group for a right-handed archer (low and right for a left-handed archer). The principle is that a slightly tail-high, outward-directed shaft is marginally less susceptible to interference following a poorer shot. The diagram shows the ‘preferred’ impact region inside the dotted lines. (Matthews and Holden, 1985)
3. As with all tests, checking the group size is recommended after any adjustment

## 5.2 Paper tear test

This test gives a good indication of both vertical and lateral adjustment. It relies on a simple indication of early arrow flight. It uses fletched shafts, but needs other equipment to hold paper in front of a target.

### Instructions:

1. Set up a target with a piece of lightweight paper (newspaper or computer fan-fold paper are usually good) suspended at least three feet from the target. (Figure 5-1 below)

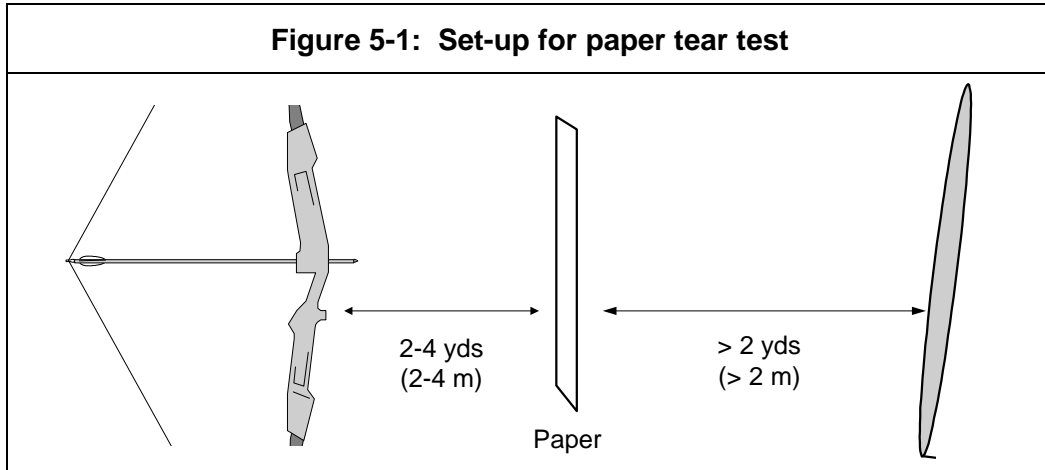

2. Shoot from about 2-3 yards from the paper, through the paper and into the target.
3. Examine the tear left by the shaft in the paper. Note where the pile and fletchings penetrated. See the diagrams below (Figure 5-2) for interpretation.

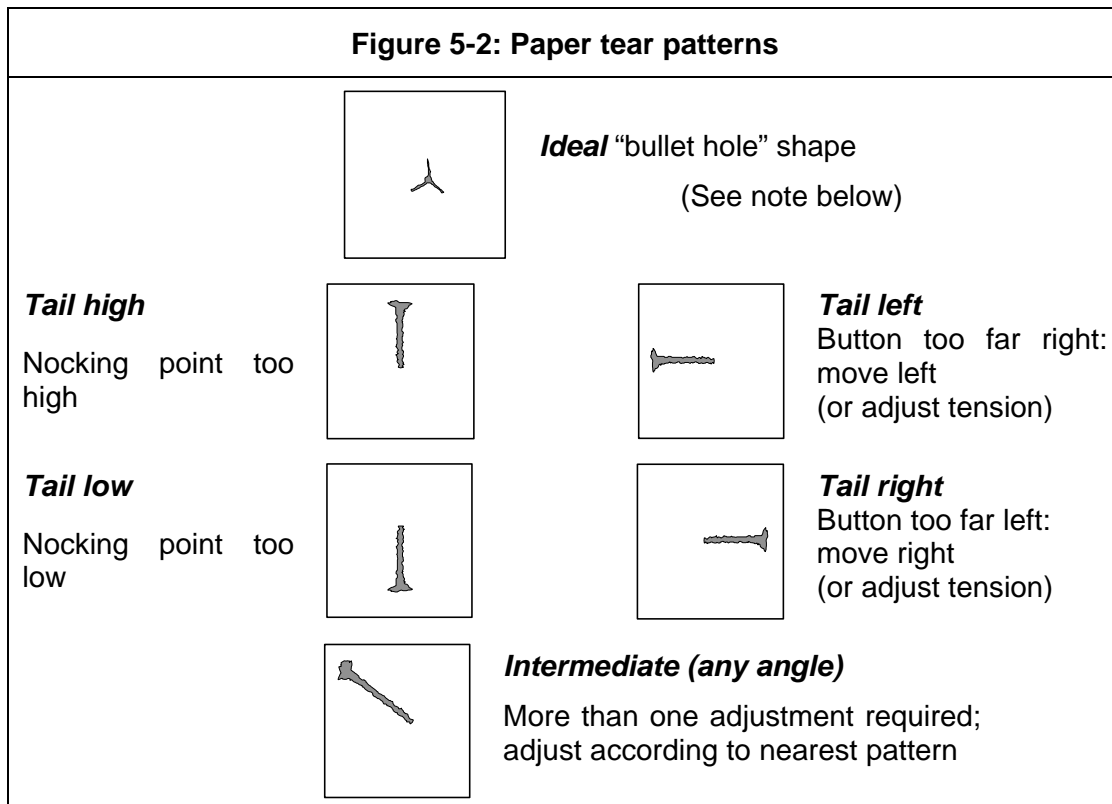

**Note:** A perfect "bullet hole" is rare - the rapidly bending shaft is rarely perfectly straight in flight at short distances. Adjust for the nearest approach to a clean 'hole'.

### 5.3 Walk-back test

A walk-back test gives a useful combined test of both centre-shot and button tension. The test should be done in calm conditions, and while you are shooting normally. In particular, you should be warmed up and have shot enough practice arrows to be close to your typical competition shooting.

#### Instructions

- i) Set up two bosses as shown (Figure 5-1, right); the lower boss will be leaning against the stand.
- ii) Place an aiming mark on the upper boss (grey spot in the diagram at right). It can be above eye level, but not too high; you may shoot above it
- iii) Shoot arrows aimed at the mark from regular distances, starting from about 5 yards and then back as far as possible. That may be every five yards or more; for light bows, perhaps every three yards. A convenient way of doing that is to shoot one from five yards, pace back five (or whatever), shoot another and so on. Re-shoot any arrows you know were poorly shot.
- iv) Check the pattern made by the arrows against the diagrams overleaf (Figure 5-2); adjust the button accordingly

Note: You will often find that the second arrow goes slightly higher than the first; if so, be careful how you interpret the patterns.

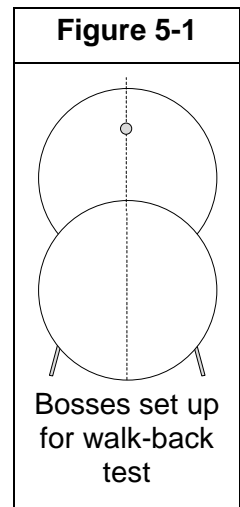

#### What the diagrams mean

The diagrams show the main patterns that you might see during walk-back tests. They all show single arrows at each distance; in practice, it is better to shoot several, and mark or record group centres for longer distances. It is also important to check before accepting any pattern (especially an 'ideal' one!) by repeating the test. Once the results are consistent, you can start adjusting the tuning.

You will often see 'patterns' that look like a mixture of those shown; particularly a combined curve and slope in the same direction. It is best to adjust one thing (tension or position) at a time to move towards the 'ideal' result.

For a walk-back test, the sight should usually be vertically above the arrow, unless there is a good reason otherwise. If it is not, patterns very like 2a and 2b can occur even with otherwise good tuning.

#### Notes:

1. 'Ideal' means that the centre shot and button tension are giving a good, clean shot in ideal circumstances (i.e. when you shoot it properly!). However, many top archers 'fine tune' either for a more forgiving shot, or directly for group size, after the walk-back test and adjustment. The walk back test is a good general set-up test.
2. Button tension is adjusted either by moving the screw adjuster controlling the spring, or changing to a different spring.
- 3: The diagrams are indicative only, and follow the majority of current texts. Some find that curved lines can result from mis-tensioning only, while off-centre positioning leads to consistent 'slope' (the other way about from the diagram). (Bearman 1997). It may be necessary to try both the adjustments in column **a** to correct a pattern to the left of centre (and either of the column '**b**' adjustments if to the right).

**Figure 5-2: Walk-back patterns**

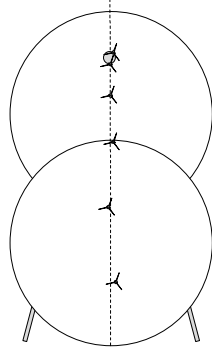

**1. Straight vertical line**

Button position and tension ideally centred.

May need further checks to get minimum group size (Note 1)

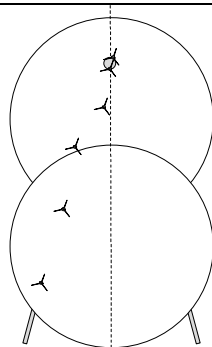

**2a: 'Slope' to Left:**

**R/H archer:** Button too stiff: reduce tension

**L/H archer:** Button too soft: increase tension

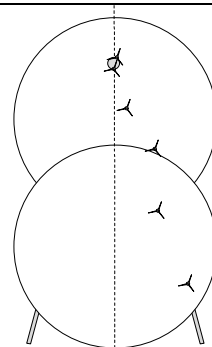

**2b: 'Slope' to Right:**

**R/H archer:** Button too soft: increase tension

**L/H archer:** Button too stiff: reduce tension

**See Note 2 on changing button tension**

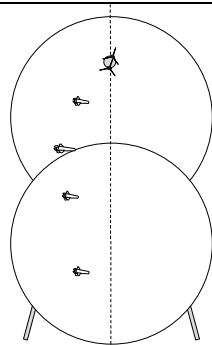

**3a: Curve to Left:**

Button too far left: move right (in for R/H archer; out for L/H archer)

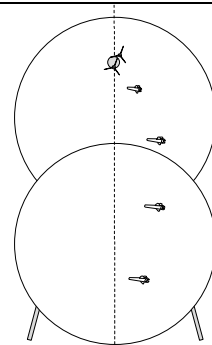

**3b: Curve to Right:**

Button too far right: move left (out for R/H archer; in for L/H archer)

NOTE: The patterns above are indicative only, and follow the majority of texts. Some find that curved lines can result from mis-tensioning only, while off-centre positioning leads to consistent 'slope' (the other way about from the diagram). It may be necessary to try both the adjustments in column a to correct a pattern to the left of centre (and either of the column b adjustments if to the right). Note, too, that a mis-set sight can also lead to patterns 2a or 2b.

## 6. Tuning for groups.

The ultimate aim of bow tuning is to achieve the best score over a full competition round. Basic bow set-up helps by removing clearance problems and ensuring clean arrow flight. Walk-back tuning helps ensure that lateral sight adjustments are minimised in normal shooting. The final 'tweak' is to tune directly for group size. The following tests do this. The principle in all cases is simple; take a particular adjustment, and move through a small range, observing the effect on group size. One then adjusts to the position giving the smallest group. 'Short distance fine tuning' uses nocking point and button tension to achieve separate vertical and lateral group control; 'micro tuning' tends to focus solely on nocking point position for recurves, or fine tiller adjustment in compounds.

### 6.1 Short distance fine tuning

#### Instructions

Set up a target at 10-15 metres, with a clear vertical and horizontal line visible. The top and side of a square 40-60cm face works well; so does white paper with a clear vertical and horizontal line drawn on it (Figure 6-1).

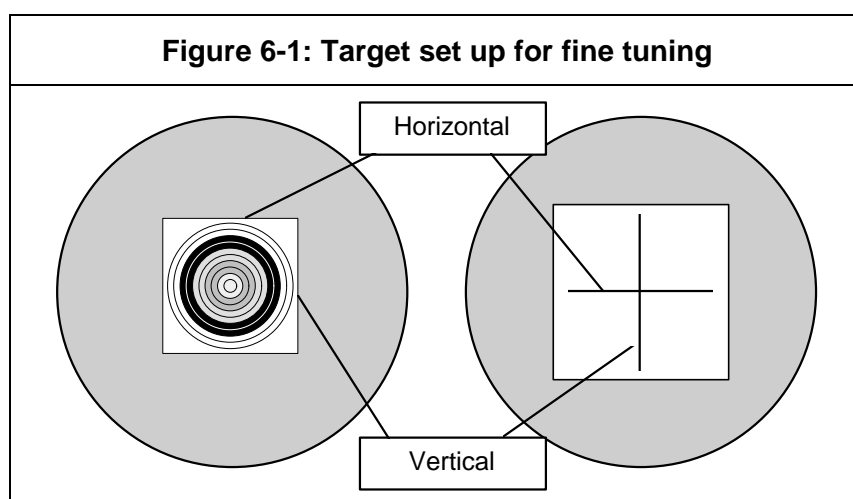

#### 1. Vertical (nocking point) tune.

- Shoot first at the horizontal line, spacing the arrows out slightly to shoot a line of arrows along the line. Note the height of the group (Figure 6-2a).
- Adjust the nocking point slightly (say, 0.5-1mm, 1/32 inch or one serving thread width), in either direction.
- Shoot at the line again. If the group height decreases, move the nocking point further in the same direction; if it increases, move it the other way. Continue moving the nocking point systematically until the group size increases again.
- Set the nocking point at the position corresponding to the smallest group height.

#### Note:

If bow tiller is adjusted by this method, it is normally recommended that the nocking point be kept at the same height above the rest/launcher while the tiller is adjusted. That will normally mean re-setting the nocking point after each tiller change. The principle is otherwise identical.

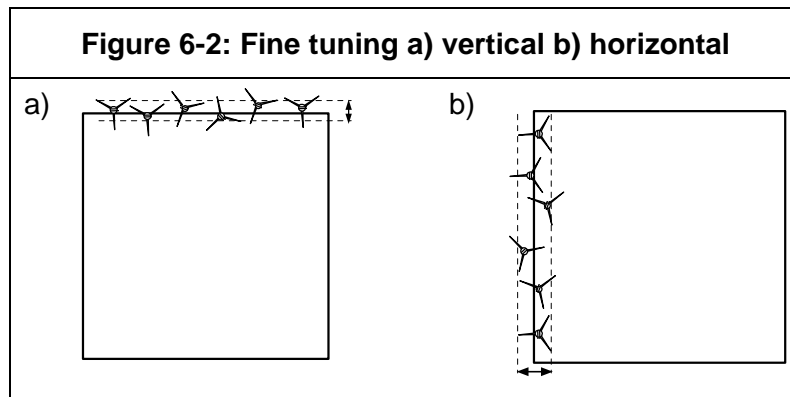

## 2. Horizontal (button) tune

- a) Shoot at the vertical line, spacing the arrows out slightly to shoot a line of arrows along the line. Note the width of the group (Figure 6-2b).
- b) Adjust the button tension slightly (say, 1/8 to 1/4 turns) in either direction.
- c) Shoot at the line again. If the group width decreases, adjust the button further in the same direction; if it increases, move it the other way. Continue adjusting systematically until the group size increases again.
- d) Set the button tension to the position corresponding to the smallest group width.

### Notes

1. It is very useful to *record* the group size, either as a list or on a graph.
2. Group size can vary considerably from end to end, just by chance. Always confirm an apparent sharp change either by repeating the test, or by checking for systematic change.

## **6.2 Fine tuning - paper plate method**

The 'paper plate' method is suggested by Tim Roberts for compound tiller tuning, and is described here for that use. However, identical principles apply for any other fine tuning adjustment, so the method could be used for a variety of adjustments.

### **Instructions**

1. Mark five or more plain paper discs with a central aiming point (8-inch paper plates are ideal). On each disc, write the planned adjustment setting. (For example, tiller may be adjusted from 'level' at 0 turns, then 1/4 turn, 1/2 turn etc.)
2. Set the bow to the first adjustment position.
3. At a distance appropriate to your grouping capability (typically 30m or more), shoot one or more ends until a reliable estimate of group size is possible.
4. Replace the first disc with the second, adjust the bow appropriately (remembering to return the nocking point to its original position if adjusting tiller - only one adjustment should change at a time) and shoot another end or two at the new plate.
5. Continue until either the progression of grouping pattern is clear and 'opens up', or the adjustment range is completed.
6. Compare groups on each disc, and select the best. Adjust the bow to the marked setting.



### **6.3 Micro tuning - McKinney/Rabska method**

*The following description follows McKinney (1996)*

Micro tuning, as described by Rick McKinney, progressively adjusts nocking point, button position and tension and finally bracing height on the basis of group size at intermediate to long distance. Note that the distances used imply a high standard of shooting - 1150+ FITA to use the method most effectively.

#### **Instructions**

1. Use a basic check such as bare shaft planing or paper tear test to get the bow set up approximately correctly, including bracing height and tiller.
2. At 30 metres, shoot with all shafts numbered but unfletched, and select those that group consistently. Check and if necessary discard any persistent 'flyers'. Fletch all but two of the consistent shafts.
3. Repeat the bare shaft planing check at 30 m using the selected shafts. Adjust nocking point and spring tension to get near impact of fletched and unfletched shafts.
4. Move to 50m and repeat, then to 60/70m.
5. At the longer distance, observe arrow flight directly. McKinney recommends that if the bare shafts 'plane' (drift consistently to one side), adjust button position; if they fishtail, adjust tension.
6. Complete the planing tests at your longest distance, continuing to adjust nocking point and spring tension to achieve close impact of bare and fletched shafts.
7. At the longest practicable distance, shoot fletched shafts and record their impact points for 30-40 arrows. Include the poor shots. Then, adjust nocking point upward slightly, and repeat (as for short distance fine tuning). Compare group sizes and patterns, and either continue adjusting in the same direction until the group degrades. Move and set the nocking point to the best position found.
8. Follow the same procedure while adjusting button spring tension.
9. Finally, adjust bracing height by 3mm (1/8 inch) either way to achieve the best group. (Note: bracing height should already have been set by sound and feel before the test)
10. Go back to a short distance (20yds or so) and perform a bare shaft planing test. Note the relative impact positions of fletched and bare shafts. Record them. In future, tune for this impact pattern after changes to equipment, with additional checks for button tension.

## 7. Books and references

---

McKinney R (1996) *The simple art of winning* Pub. Leo Planning

Matthews R. (1980) *Bow Tuning* Avail. D G Quick

Matthews R and Holden J (1985), *Archery in Earnest* Crowood Press, Ramsbury, Wilts, UK. ISBN 1-86126-089-X (paperback 1997)

Bearman K (ed.) (1997). GNAS Coaching Manual. Grand National Archery Society, UK